

DECK CONSTRUCTION REQUIREMENTS



Any deviation or alternative methods to these requirements require approval by the Building Department prior to construction and may require additional plan submissions or engineering.

This handout is intended only as a guide and is based in part on the 2020 Minnesota Residential Code, City ordinances, and good building practice. While every attempt has been made to insure the correctness of this handout, no guarantees are made to its accuracy or completeness. Responsibility for compliance with applicable codes and ordinances falls on the owner or contractor. For specific questions regarding code requirements, refer to the applicable codes or contact the Baxter Building Department.

DECK BUILDING PERMITS

Building permits are required for decks with the following exception: freestanding decks, regardless of size, if they are not more than 30 inches above adjacent grade. Freestanding decks do not require footings that extend below the frost depth.

Building permits are not required for patios made of concrete or pavers on grade.

Building permits can be obtained from the Building Department by filling out all application documents and submitting your construction documents.

PLANS

The Building Department has a handout illustrating what needs to be included on deck plans. It is very important that your plans depict exactly how your deck will be built. Plans must be neat and be of a scale of at least $\frac{1}{4}'' = 1'$. Computer generated plans from home stores are acceptable provided all additional required information is included. Also include any composite decking/rail system "Acceptance Reports" (see pages 4 and 19). Reports can be found on the manufacturers' website, or:

- http://www.icc-es.org/Evaluation_Reports/ or,
- <http://www.10klakes.org/Uniformity/2013/PLASTICD.pdf>

*Pay close attention to stair stringer spacing for composite stair treads.

PLEASE REVIEW THE PLANS WHEN THEY ARE RETURNED TO YOU SO THAT YOU WILL BE AWARE OF ANY CORRECTIONS NEEDED.

INSPECTIONS

1. Call in advance
2. Have address, permit number, and type of inspection (ex. footing) ready
3. Footing Inspection - Holes dug, loose material/water removed. Diamond Pier footings are approved for use.
4. Framing Inspection – Required if any portion of structural framing will be covered prior to Final Inspection, or, if permit holder requests framing inspection prior to installing decking.
5. Final Inspection - All work complete and all stairs, handrails, and guards in place. **Have plans and permit card on-site. Have installation instructions for composite decking/railing on site.**
6. If work is approved, the inspector will sign the record card and you may proceed with the next step
7. If corrections are noted, a correction notice will be left on the site. If a re-inspection is required it will be noted on the notice.

Please do not hesitate to call the Building Department at 218-454-5109 if you have questions. If necessary, we will be happy to meet with you on the site to help resolve any concerns or problems.

TERMINOLOGY

1. RAIL TOP CAP
2. BALLUSTERS
3. RAIL POST
4. SUPPORT POST
5. RIM OR BAND JOIST
6. DECKING
7. JOISTS
8. POST BASE CONNECTOR
9. PIER
10. FOOTING
11. DROP BEAM
12. BLOCKING
13. HOUSE JOIST
14. 1/2" BOLTS
15. LEDGER BOARD
16. FLASHING

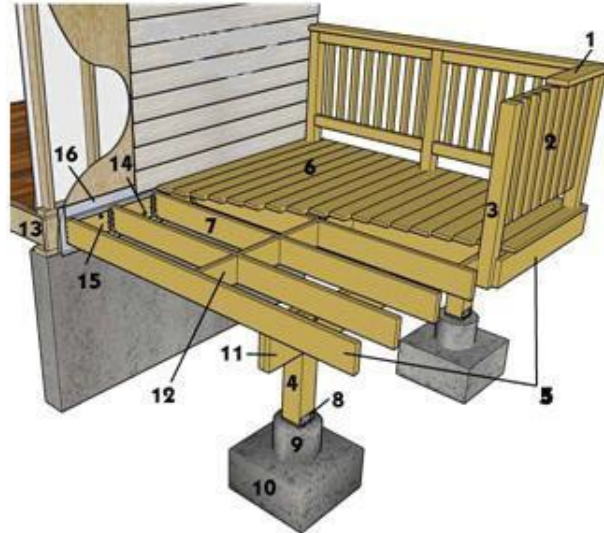

THINK YOU MIGHT ENCLOSE YOUR DECK IN THE FUTURE?

Deck plans are approved on the assumption that the deck will be used only as a deck for the life of the structure. Because footing sizes, setbacks, structural supports, and a host of other deck components are different for enclosed spaces than they are for decks, it is important that you indicate on your plans the desire to convert the deck at a future date. You should then design your deck to carry future loads and meet setbacks and other rules.

ZONING REGULATIONS

Decks are permitted as an addition to a dwelling in a side or rear yard or as a freestanding structure. An accurate site plan/survey showing the deck location must be submitted with the construction plans for review. Setbacks are routinely checked as a part of the plan review and again at the time of the footing inspection. Unless otherwise permitted by the Building department, lot lines must be marked and survey markers exposed. A site inspection may be required to verify actual deck/stair locations.

*Easements, wetland buffers and other lot restrictions may require greater setbacks than permitted by the zoning ordinance. **The most restrictive setback applies.** Questions regarding zoning regulations should be directed to the Planning and Zoning Office*

Clearances:

Well:	3 feet to footing or deck overhang
Septic Tank:	10 feet
Drainfield:	20 feet
Overhead Electrical:	10 feet including drip leg
Existing Intakes/Exhausts:	Maintain manufacturers clearances

Call Gopher State One Call for utility locations at least two working days before you dig – 1-800-252-1166 or 651- 454-0002.



ELECTRICAL

NEC 210.52(E)(3) Balconies, decks and porches, regardless of size, that are accessible from inside a dwelling unit shall have at least one receptacle installed within the perimeter.

R303.7 Exterior stairways shall be provided with a means to illuminate the stairs, including the landings and treads. Exterior stairways shall be provided with an artificial light source located in the immediate vicinity of the top landing of the stairway.

The illumination of exterior stairways shall be controlled from inside the dwelling unit.

Exception: Lights that are continuously illuminated or automatically controlled.

MATERIALS

Fasteners

Nails and other hardware must be hot-dipped zinc-coated (galvanized), stainless steel or equal. Screws should be either hot-dipped galvanized or electroplated with a polymer coating. 12d nails are recommended on nominal 2-inch decking. 10d nails are recommended for 5/4" decking.

With lag screws, use a flat washer under the head. Use washers under the nut and head of machine bolts and just under the nut of carriage bolts.

Lumber

All wood used in deck construction must be pressure treated lumber or wood that is naturally resistant to decay such as redwood or cedar.

Wood used above ground, in contact with the ground, or below ground requires different degrees of treatment. Check the labels of the material you are buying to determine where it can be used. *Because some preservative treatments are very corrosive, make sure that any fasteners or metal connectors used in the construction of your deck are approved by the manufacturer for use with treated wood.*

DECKING

Materials commonly used for decking include standard dimension lumber (either 2X4 or 2X6), radius-edged decking, or a manufactured decking product.

Radius-edged Patio Decking (5/4 decking) has been specifically developed for outdoor decks. *Redwood and cedar patio decking is intended to be used flat-wise in load-bearing applications where spans do not exceed 16" o.c. (12" o.c. when installed diagonally to joists). Southern pine decking may span 24" o.c. or 16" o.c. when installed diagonally to joists.*

Manufactured decking products may be used only when meeting ASTM D 7032 or when approved by the Building Department. Approval is based on the material carrying an ICC Evaluation Services Report. Decking without a report will not be approved. Ask the decking supplier to provide you with a copy of the research report. The Building Department maintains a list of composite decking materials that meet US building codes that is available upon request. **Caution – some manufactured deck products are approved for decking but not for stair treads. In some cases where manufactured decking is approved for stairs, the spacing of supports may be significantly reduced compared to use on the deck itself. Read the research report for further information.**

MAXIMUM DECK BOARD SPANS	
2x6 OR 5/4 SOUTHERN PINE PERPENDICULAR TO JOIST	24" O.C.
5/4 CEDAR OR REDWOOD AND 2X4 PERPENDICULAR TO JOIST OR 5/4 SOUTHERN PINE OR 2X6 AT 45 DEGREES TO JOIST	16" O.C.
5/4 AND 2X4 AT 45 DEGRESS TO JOIST	12" O.C.

FOOTINGS

Footings supporting a 4x4 column must be not less than 6-inch diameter. Post footings supporting columns larger than 4x4 must be 8-inch diameter or larger. The bottom of post footings may be "belled" to achieve the desired minimum bearing area. The base of the footing must be at least **50 inches** below finished grade. Rebar is recommended. Center the column on the footing secured by a pin or connector. Posts embedded in the ground must be 60% C.C.A. or equal. Using a fiberboard tube will allow elevation of the top of the footing above finished grade to provide protection of the wood post from lawn mowers and trimmers.

UNDERSTANDING LOAD PATHS

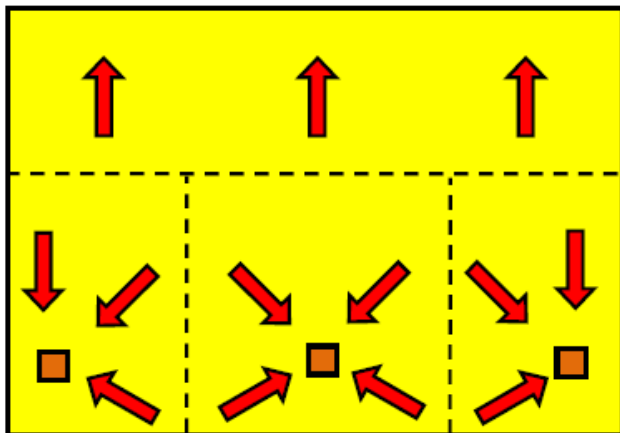

Loads are assumed to be uniform across the floor

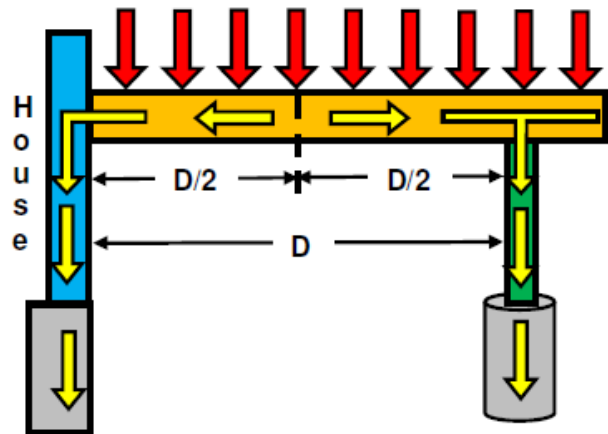

Deck footings should be sized according to the following table. Footings must extend **at least 60 inches below grade** (frost line) except for decks that are not connected to a dwelling. **The minimum compressive strength of concrete used for deck footings is 2500 psi.**

DECK FOOTING SIZES (1500 psf soils) – NOT FOR USE WITH HOT TUBS							
Max. Area of Deck Supported in Sq Ft	Footing Diameter Required in Inches	Max. Area of Deck Supported in Sq Ft	Footing Diameter Required in Inches	Max. Area of Deck Supported in Sq Ft	Footing Diameter Required in Inches	Max. Area of Deck Supported in Sq Ft	Footing Diameter Required in Inches
10	8	23	12	41	16	65	20
13	9	27	13	47	17	72	21
16	10	32	14	53	18	79	22
19	11	36	15	59	19	86	23

Required footing sizes are determined by calculating the area of the deck supported by each footing. Loads shall be assumed to be equally shared between the supporting elements. **Don't overlook cantilevers. The minimum compressive strength of concrete used for deck footings is 2500 psi.**

THE REQUIRED AREA OF THE COLUMN SHOULD FULLY BEAR ON THE FOOTING

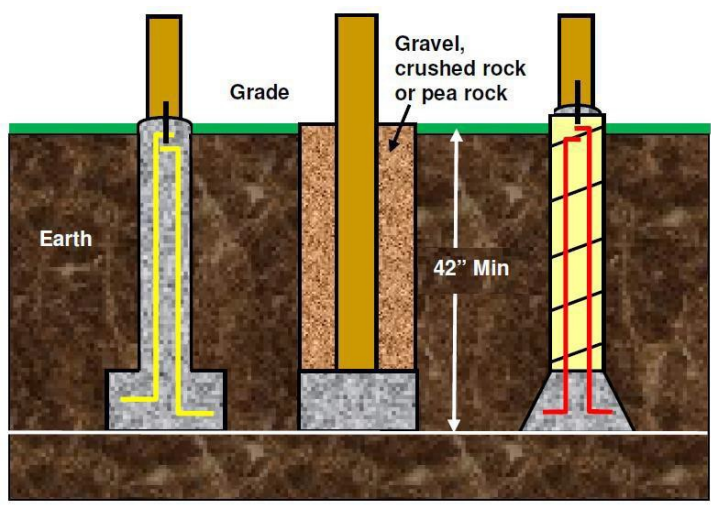
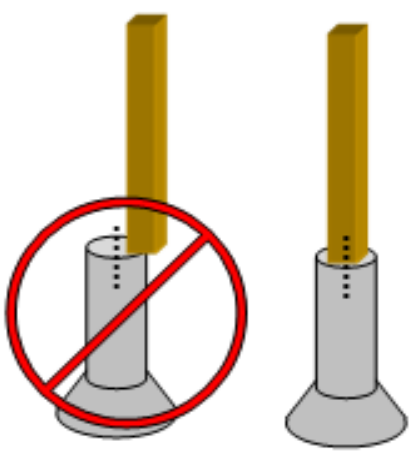

The minimum compressive strength of concrete used for deck footings is 2500 psi.

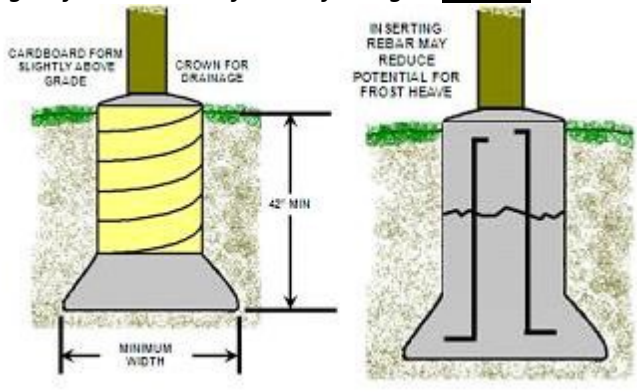

WHERE DO I PUT MY FOOTINGS?

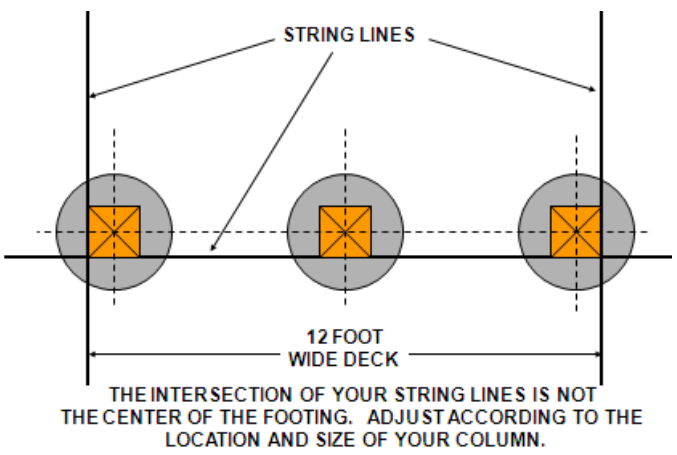
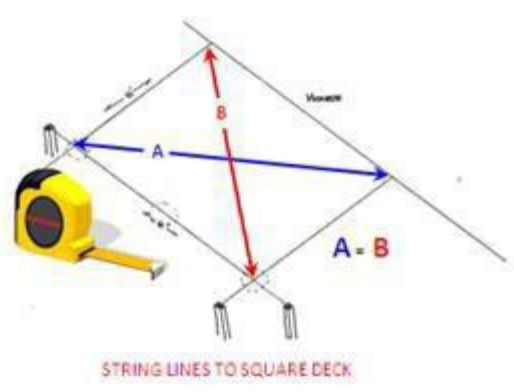

ANCHORING POST BASE

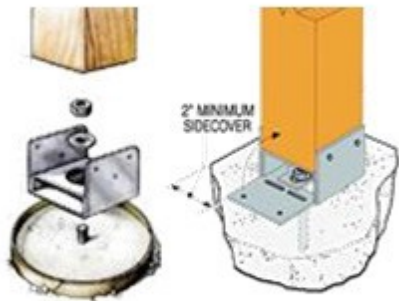

Follow manufacturers installation specifications.

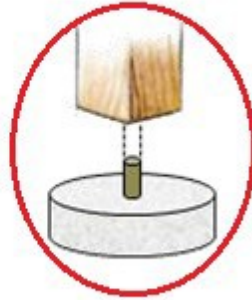

Not allowed - connection must be made using a field inspectable means of connection.

DECKFRAMING ATTACHMENT OF LEDGER BOARD TO WOOD JOISTS (2X6, 2X8, 2X10, 2X12) (Caution: 2x6 and 2x8 joists will require underside floor protection with 5/8" treated plywood)

Make sure the ledger is securely attached to the dwelling. Install metal flashing at top and caulk sides.

TABLE R507.2
FASTENER SPACING FOR A SOUTHERN PINE OR HEM-FIR DECK LEDGER AND A 2-INCH-NOMINAL SOLID-SAWN SPRUCE-PINE-FIR BAND JOIST^{c, f, and g}
(Deck live load = 40 psf, deck dead load = 10 psf)

JOIST SPAN	6' and less	6'1" to 8'	8'1" to 10'	10'1" to 12'	12'1" to 14'	14'1" to 16'	16'1" to 18'
Connection details	On-center spacing of fasteners^{a and e}						
½ inch diameter lag screw with 3/32 inch maximum sheathing ^a	30	23	18	15	13	11	10
½ inch diameter bolt with 3/32 inch maximum sheathing	36	36	34	29	24	21	19
½ inch diameter bolt with 3/32 inch maximum sheathing and ½ inch stacked washers ^{b, h}	36	36	29	24	21	18	16

- a. The tip of the lag screw shall fully extend beyond the inside face of the band joist.
- b. The maximum gap between the face of the ledger board and face of the wall sheathing shall be ½ inch.
- c. Ledgers shall be flashed to prevent water from contacting the house band joist.
- d. Lag screws and bolts shall be staggered in accordance with Section R507.2.1.
- e. Deck ledger shall be minimum 2 × 8 pressure-preservative-treated No. 2 grade lumber, or other approved materials as established by standard engineering practice.
- f. When solid-sawn pressure-preservative-treated deck ledgers are attached to a minimum 1-inch-thick engineered wood product (structural composite lumber, laminated veneer lumber or wood structural panel band joist), the ledger attachment shall be designed in accordance with accepted engineering practice.
- g. A minimum 1 × 9½ Douglas Fir laminated veneer lumber rimboard shall be permitted in lieu of the 2-inch nominal band joist.
- h. Wood structural panel sheathing, gypsum board sheathing or foam sheathing not exceeding 1 inch in thickness shall be permitted. The maximum distance between the face of the ledger board and the face of the band joist shall be 1 inch.

Capacity of lag or carriage bolts shall not exceed 400 lb's per bolt unless design provided.

TABLE 507.2.1
PLACEMENT OF LAG SCREWS AND BOLTS IN DECK LEDGERS AND BAND JOISTS
MINIMUM END AND EDGE DISTANCES AND SPACING BETWEEN ROWS

	TOP EDGE	BOTTOM EDGE	ENDS	ROW SPACING
Ledger ^a	2 inches ^d	¼ inch	2 inches ^b	1 ½ inch
Band Joist	¾ inches	2 inches	2 inches ^b	1 ½ inch ^c

- a. Lag screws or bolts shall be staggered from the top to the bottom along the horizontal run of the deck ledger in accordance with Figure R507.2.1(1).
- b. Maximum 5 inches.
- c. For engineered rim joists, the manufacturer's recommendations shall govern.
- d. The minimum distance from bottom row of lag screws or bolts to the top edge of the ledger shall be in accordance with Figure R507.2.1(1).

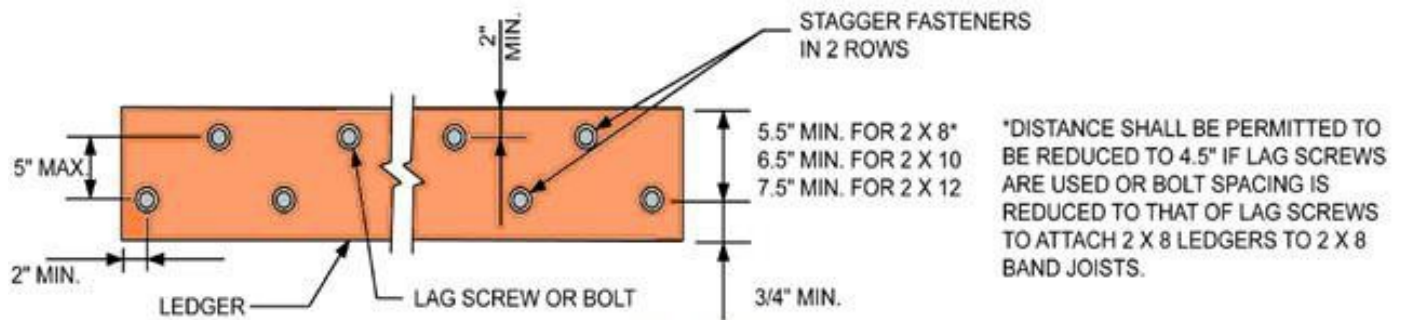
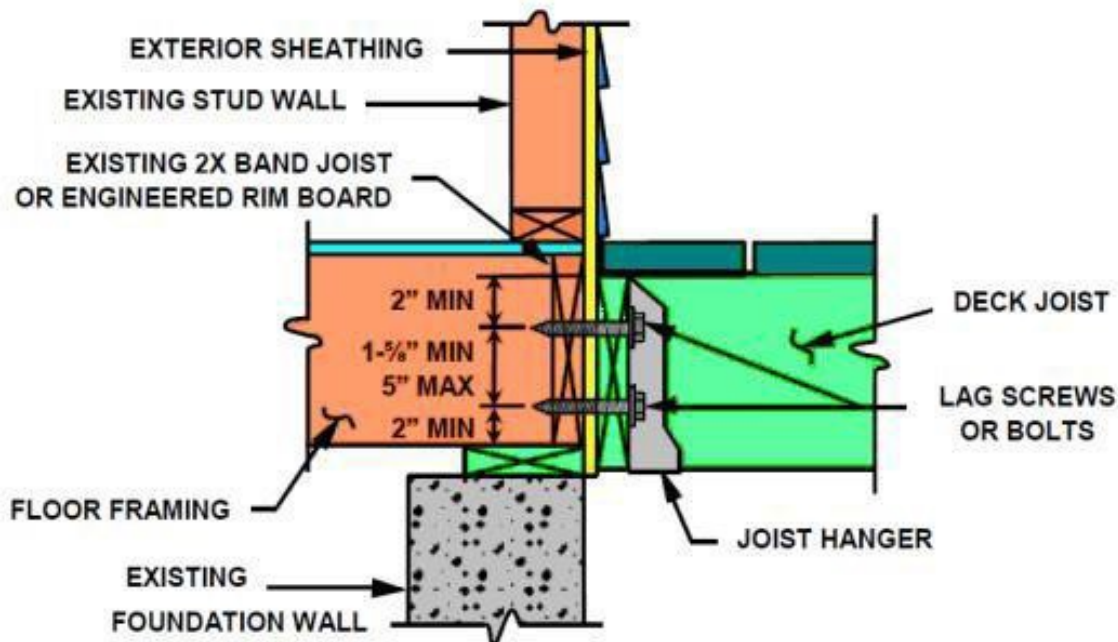
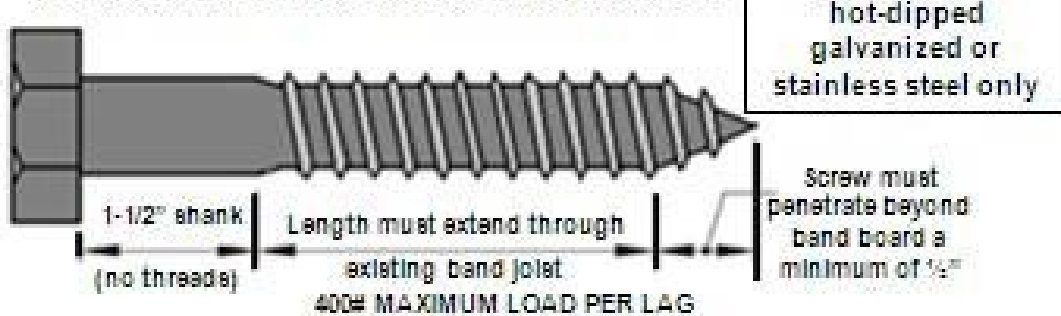

FIGURE R507.2.1(1)
PLACEMENT OF LAG SCREWS AND BOLTS IN LEDGERS

PLACEMENT OF LAG SCREWS AND BOLTS IN BAND JOISTS



1/2" DIAMETER LAG SCREWS MINIMUM



Ledger Lock or other engineered screws can be used

LEDGER FLASHING DETAIL

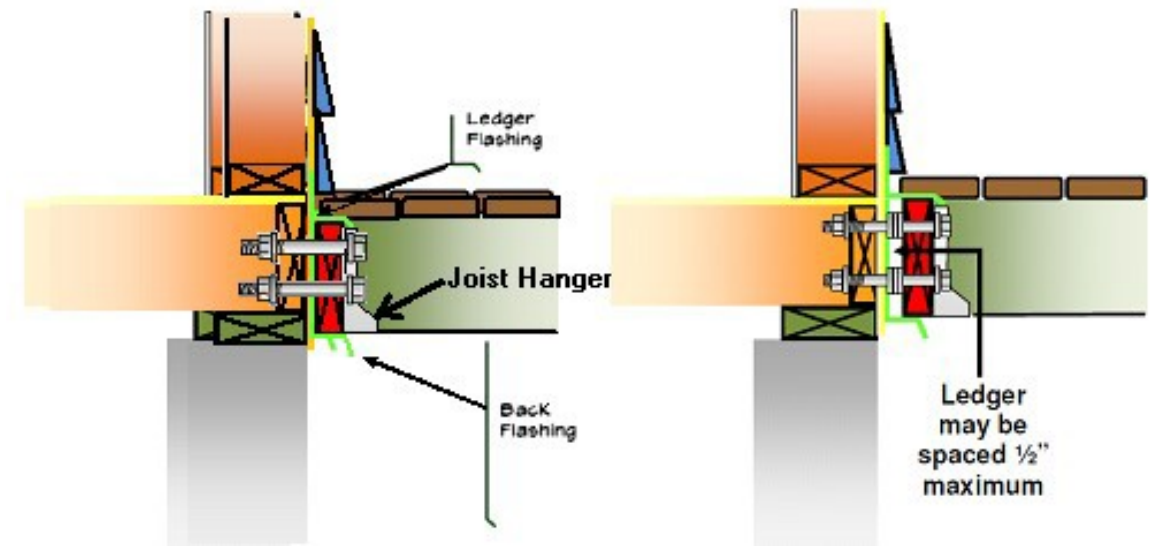

LATERAL LOAD CONNECTIONS TWO MINIMUM PER DECK

(See "Alternate Methods" page 10)

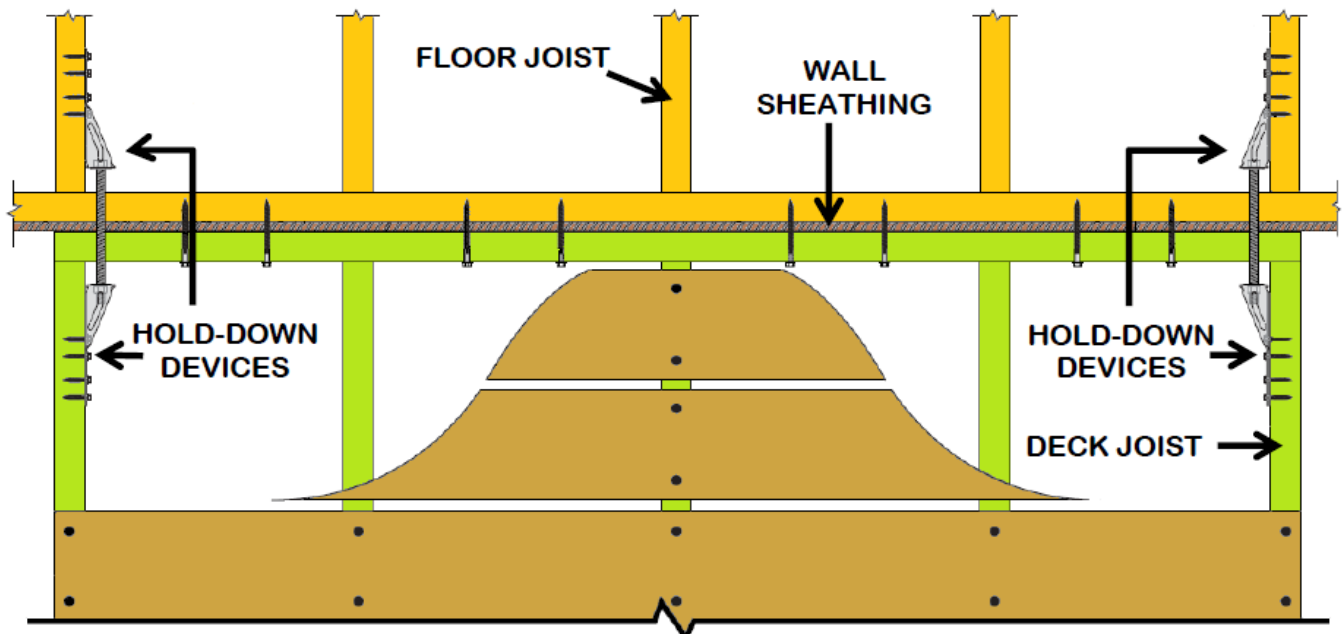

- HOLD-DOWN TENSION DEVICES MUST BE INSTALLED IN NOT LESS THAN TWO LOCATIONS PER DECK
- EACH DEVICE MUST HAVE AN ALLOWABLE STRESS DESIGN CAPACITY OF NOT LESS THAN 1500 POUNDS.
- FLOOR SHEATHING IN THE DWELLING MUST BE NAILED TO THE JOISTS TO WHICH HOLD DOWNS ARE CONNECTED AT 6" MAXIMUM O.C.
- ALTERNATIVELY THE DECK MAY BE DESIGNED TO BE SELF SUPPORTING OR A DESIGN MAY BE PROVIDED BY A LICENSED DESIGN PROFESSIONAL.

**FLOOR JOISTS
PERPENDICULAR TO DECK
LEDGER**

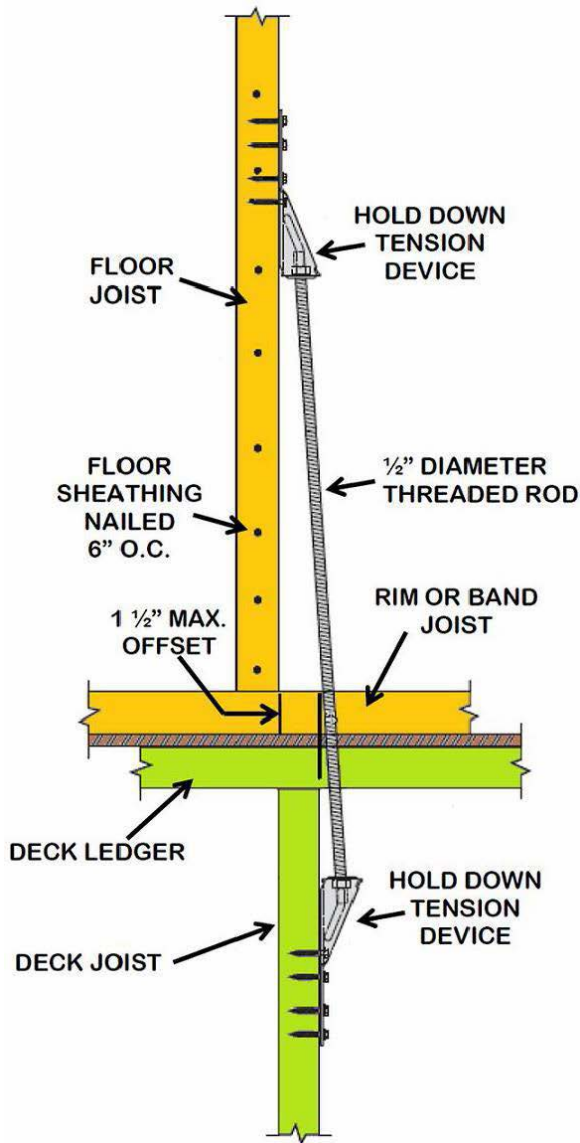

**FLOOR JOISTS
PARALLEL TO DECK
LEDGER**

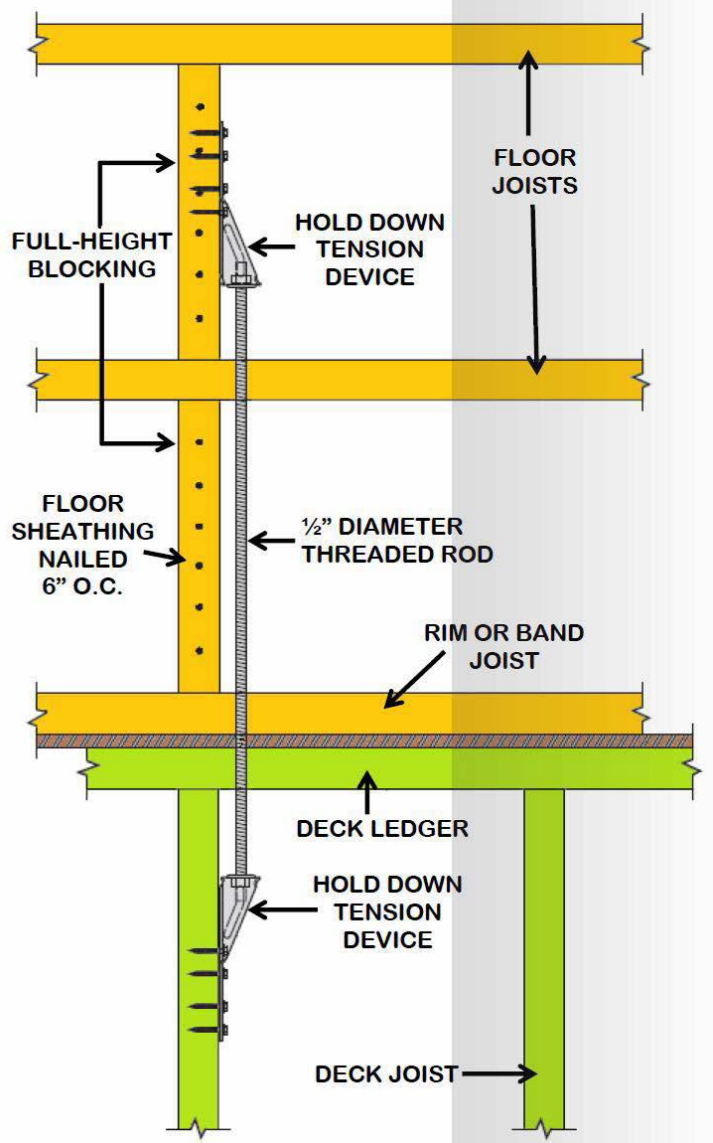

**WHEN THERE IS NO ACCESS TO THE
TOP OF THE FLOOR SHEATHING**

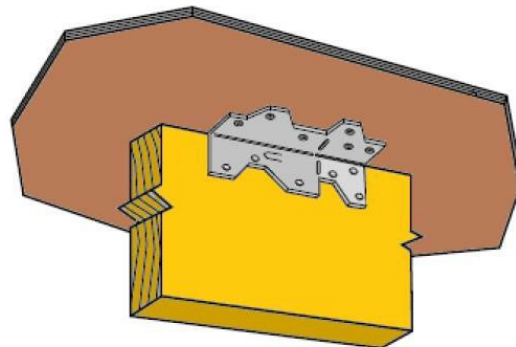

**INSTALL APPROVED CONNECTORS PER THE
MANUFACTURER'S INSTALLATION INSTRUCTIONS**

IN ALL CASES, MANUFACTURE'S INSTALLATION INSTRUCTIONS MUST BE FOLLOWED

ALTERNATIVE DECK LATERAL LOAD CONNECTORS (or approved equivalent)
Can be used on new and existing decks. It is easier to install.



LTS19-TZ
Deck Lateral Load Connector

The LTS19-TZ holdown can be used to build stronger, safer, deck structures. It will meet the new lateral connection requirements outlined in the 2015 International Residential Code (IRC) by attaching deck floor joist members to the main structure. The LTS19-TZ can also be used for deck rail post reinforcement.

Materials: Strap: 16Ga G-185 galvanizing
 Washer - 3Ga USP primer

Codes: ER-200, FL14500

Installation:

- The LTS19-TZ must be installed flush to the surface of the outside wall of the home.
- Use the building code specified 3/8" lag screw and washer to secure the base of the LTS19-TZ to the main house structure. The minimum embedment depth for the lag screw is 3".
- Tighten lag screw until snug to the base of the LTS19-TZ, with a wrench or socket, to prevent loosening of the lag screw.
- Use all specified 10d common nails to attach the strap portion of the connector to the bottom of the deck floor joist.
- See additional installation instructions on detail drawing.

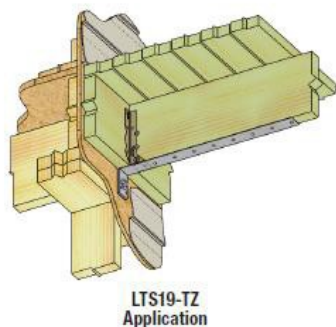

Decks & Fences

DTT Deck Tension Ties

DTT tension ties are safe, cost-effective connectors designed to meet or exceed code requirements for deck construction. These versatile DTT connectors are also load rated as a holdown for light-duty shearwalls and braced wall panel applications.

For new construction or to make an existing current deck code-compliant, the DTT1Z can be used as a tension-tie to satisfy the 2015 IRC provision for a 750 lbs. lateral load connection to the house at four locations per deck. This new code detail permits the lateral connection from the deck joists to be made to top plates, studs, or headers within the supporting structure, which eliminates the need to access to the floor joists inside the home.

The new DTT1Z fastens to the narrow or wide face of a single 2x with Simpson Strong-Tie® Strong-Drive® SD Connector screws or nails and accepts a 3/8" machine bolt, anchor bolt, or lag screw (*washer required*) or can be installed with the new Strong-Drive SDWH Timber-Hex HDG screw with an integral washer. The DTT2 fastens easily to the wide face of a single or double 2x using Simpson Strong-Tie Strong-Drive SDS Heavy-Duty Connector screws (included) and accepts a 1/2" machine bolt or anchor bolt.

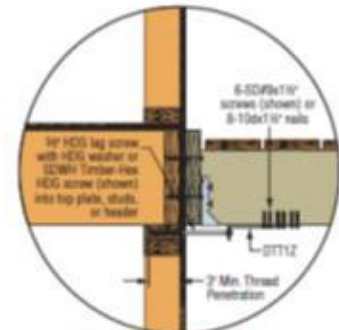

Typical DTT1Z Deck-to-House Lateral Load Connection
 For more information on lateral load connections, see technical bulletin T-DECKLALOAD

DTT1Z
 U.S. Patent Pending

MATERIAL: 14 gauge

FINISH: DTT1Z/DTT2Z—ZMAX® coating;

DTT2SS—Stainless steel; see Corrosion Information, pages 13-15.

INSTALLATION:

- Use all specified fasteners. See General Notes.
- A standard cut washer (*included*) must be installed between the nut and the seat.
- Simpson Strong-Tie Strong-Drive SDS Heavy-Duty Connector screws install best with a low speed high torque drill with a 3/8" hex head driver.
- Strong-Drive SD Connector screws install with a 1/4" hex head driver.
- Strong-Drive SDWH Timber-Hex HDG screws install with a 1/2" hex head driver.

BEAMS

Construct beams using two or more 2 inch nominal pieces of lumber. Nail beams together using 10d nails at 32 inches o.c. along each edge of the beam and staggered. A spacer may be used to fir the beam to a 3½ -inch width. Beams should be installed with any arch or crown facing up. Attachments to columns should be with post caps designed for such use. Splices must occur over columns.

BEAM SPANS (Wet Service) (Center of one column to center of next) (Source AF&PA; rev. 8-17-10)								
Species	B e a m	Joist Spans						
		6'	8'	10'	12'	14'	16'	18'
Southern Pine	2-2X6	7'1"	6'2"	5'6"	5'0"	4'8"	4'4"	4'1"
	2-2X8	9'2"	7'11"	7'1"	6'6"	6'0"	5'7"	5'3"
	2-2X10	11'10"	10'3"	9'2"	8'5"	7'9"	7'3"	6'10"
	2-2X12	13'11"	12'0"	10'9"	9'10"	9'1"	8'6"	8'0"
	3-2X6	8'7"	7'8"	6'11"	6'3"	5'10"	5'5"	5'2"
	3-2X8	11'4"	9'11"	8'11"	8'1"	7'6"	7'0"	6'7"
	3-2X10	14'5"	12'10"	11'6"	10'6"	9'9"	9'1"	8'7"
	3-2X12	17'5"	15'1"	13'6"	12'4"	11'5"	10'8"	10'1"
Cedar, Redwood , Ponderosa Pine	2-2X6	5'5"	4'8"	4'2"	3'10"	3'6"	3'1"	2'9"
	2-2X8	6'10"	5'11"	5'4"	4'10"	4'6"	4'1"	3'8"
	2-2X10	8'4"	7'3"	6'6"	5'11"	5'6"	5'1"	4'8"
	2-2X12	9'8"	8'5"	7'6"	6'10"	6'4"	5'11"	5'7"
	3-2X6	7'4"	6'8"	6'0"	5'6"	5'1"	4'9"	4'6"
	3-2X8	9'8"	8'6"	7'7"	6'11"	6'5"	6'0"	5'8"
	3-2X10	12'0"	10'5"	9'4"	8'6"	7'10"	7'4"	6'11"
	3-2X12	13'11"	12'1"	10'9"	9'10"	9'1"	8'6"	8'1"

METHODS OF ATTACHING BEAM TO COLUMN

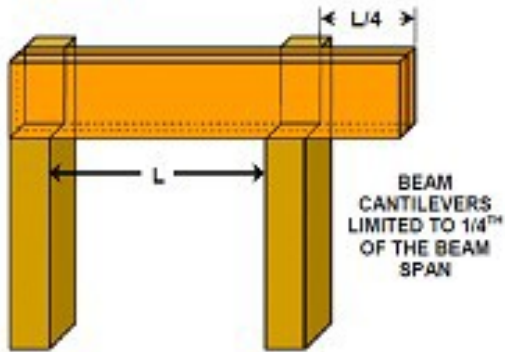
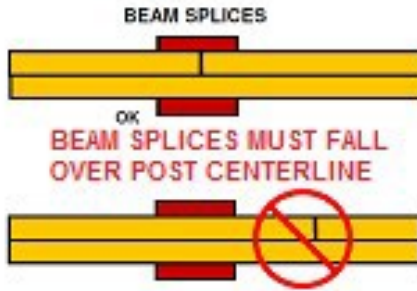
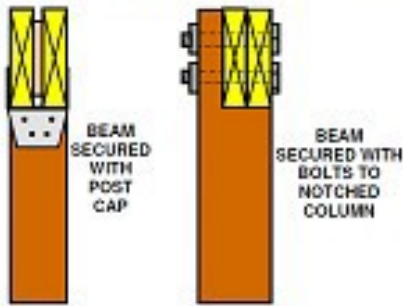

COLUMNS

MAXIMUM POST HEIGHT IN FEET

SPECIES	SIZE	SQUARE FEET OF DECK SUPPORTED													
		36	48	60	72	84	96	108	120	132	144	156	165	180	192
SOUTHERN PINE	4X4	10	10	10	9	9	8	8	7	7	6	6	6	6	6
	4X6	14	14	13	12	11	10	10	9	9	8	8	8	7	7
	6X6	17	17	17	17	17	17	17	17	16	16	15	14	13	13
REDWOOD CEDAR	4X4	10	10	9	8	7	7	6	6	5	4				
	4X6	14	13	12	11	10	9	8	8	7	7	7	6	6	5
	6X6	17	17	17	17	17	16	13	7						

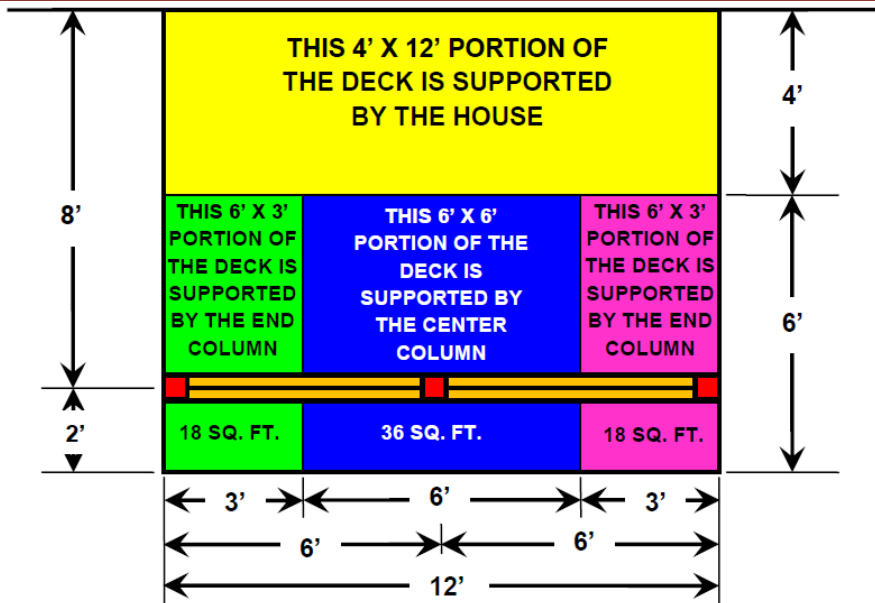

JOISTS

JOIST SPANS (Wet Service)

(Source AF&PA; rev. 8-17-10)

JOIST SIZE	SOUTHERN PINE			WESTERN CEDAR/PONDEROSA PINE		
	12" oc	16" oc	24" oc	12" oc	16" oc	24" oc
2X6	10'4"	9'5"	7'10"	8'10"	8'0"	7'0"
2X8	13'8"	12'5"	10'2"	11'8"	10'7"	8'8"
2X10	17'5"	15'10"	13'5"	14'11"	13'0"	10'7"
2X12	21'2"	18'10"	15'5"	17'5"	15'1"	12'4"

JOIST DETAILS

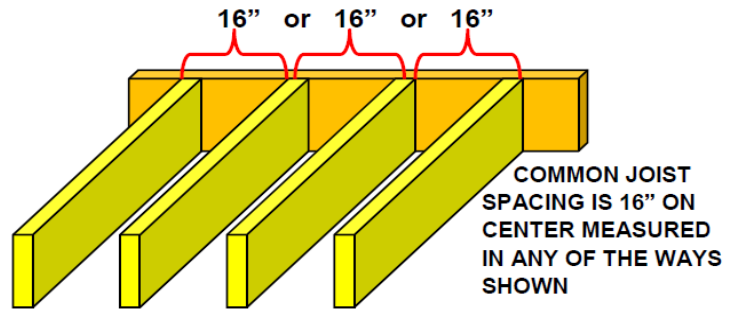
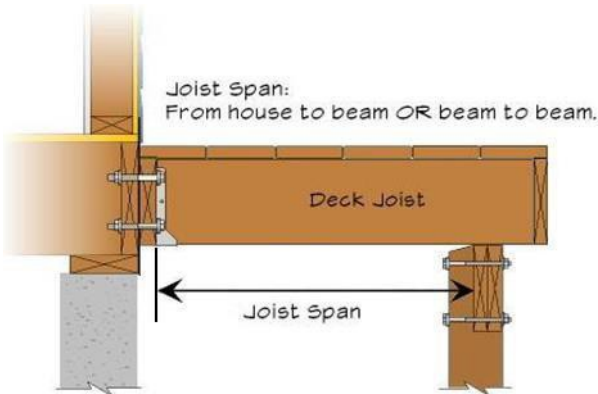

Joist spacing is determined by the type of decking used. 16" o.c. spacing must be used with 5/4 decking or when 2x6 or 2x4 decking is used at a 45° angle. 12" o.c. spacing required when 5/4 decking is used at a 45° angle.

WOOD DECKING

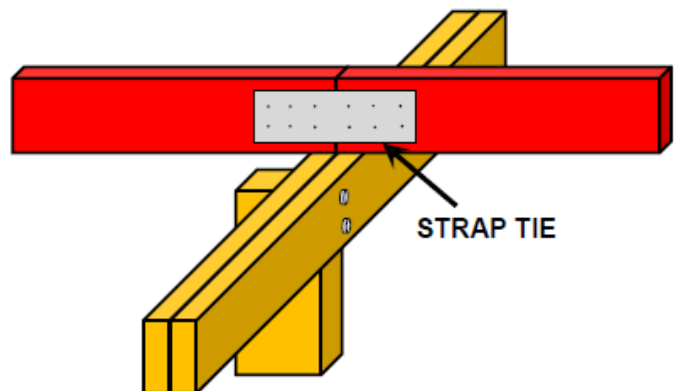
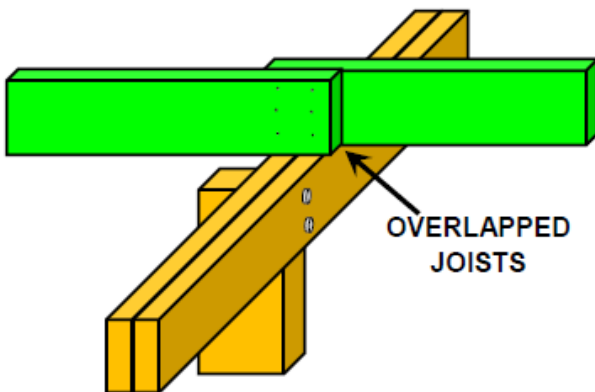
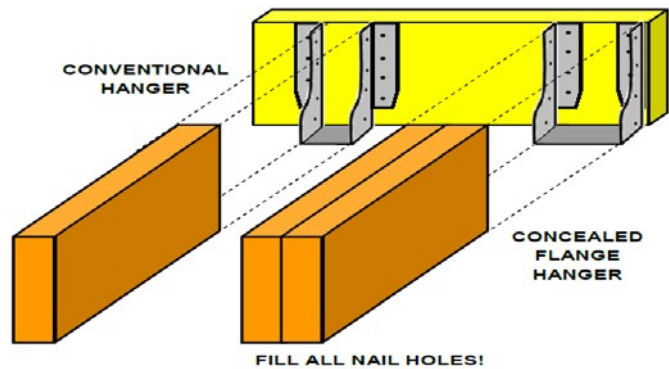
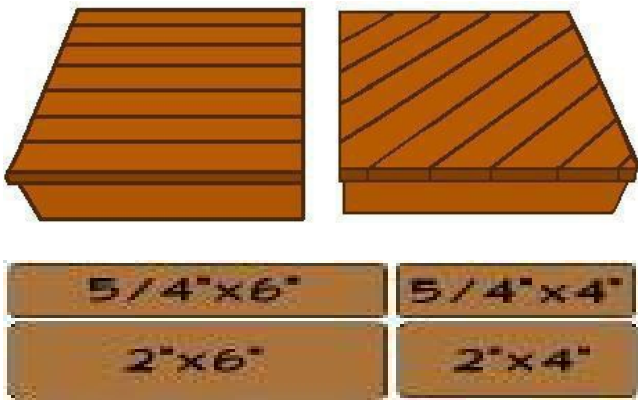

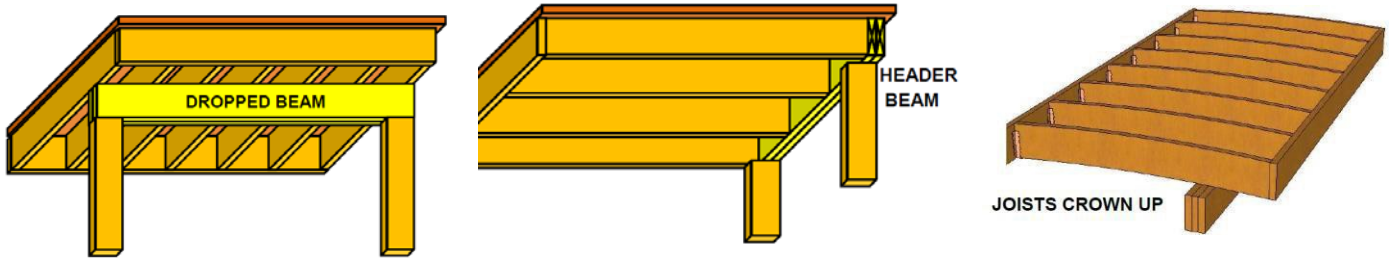

JOIST TO BEAM ATTACHMENTS

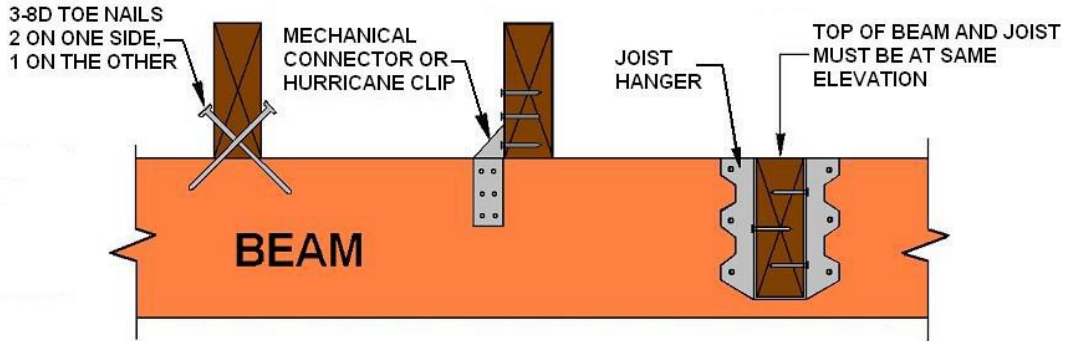

Joists must bear on a beam, ledger strip, or joist hangers. Joist hangers must be installed in accordance with the manufacturer's recommendations. **Fill all nail holes in joist hangers.**

RIM JOIST ATTACHED TO LEDGER WITH CONCEALED FLANGE HANGER

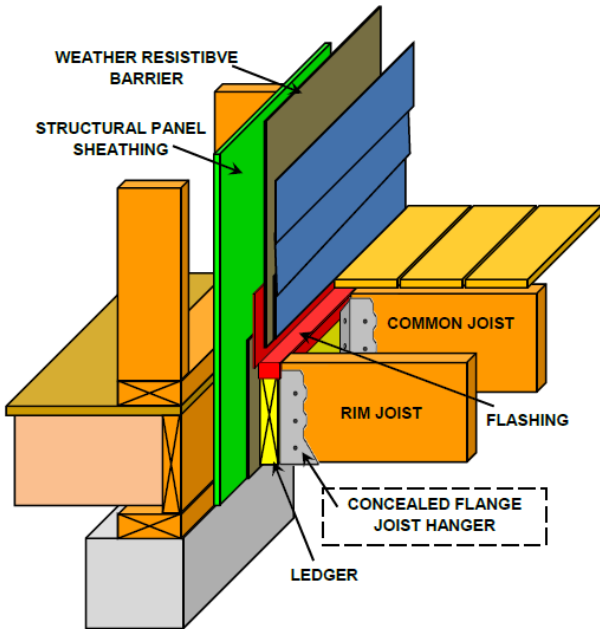

RIM JOIST ATTACHED TO LEDGER BY END NAILING - NOT ALLOWED

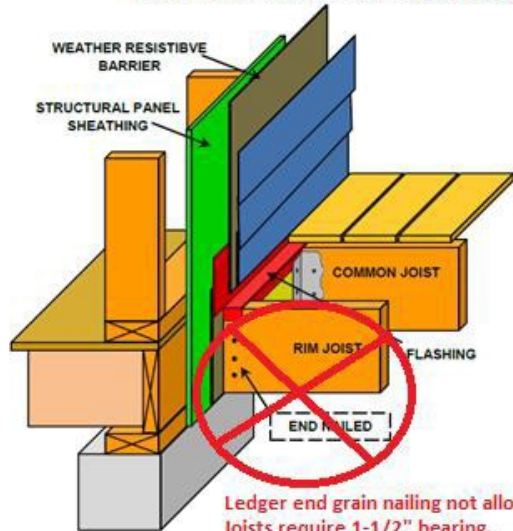

Ledger end grain nailing not allowed. Joists require 1-1/2" bearing. Use approved concealed flange hanger.

CANTILEVERS

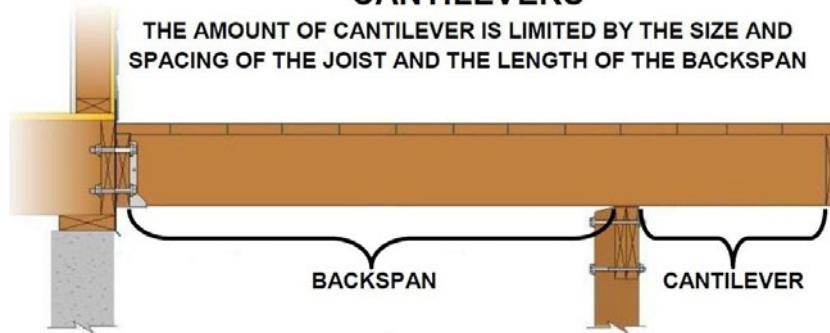

SPECIAL FLOOR FRAMING DETAILS

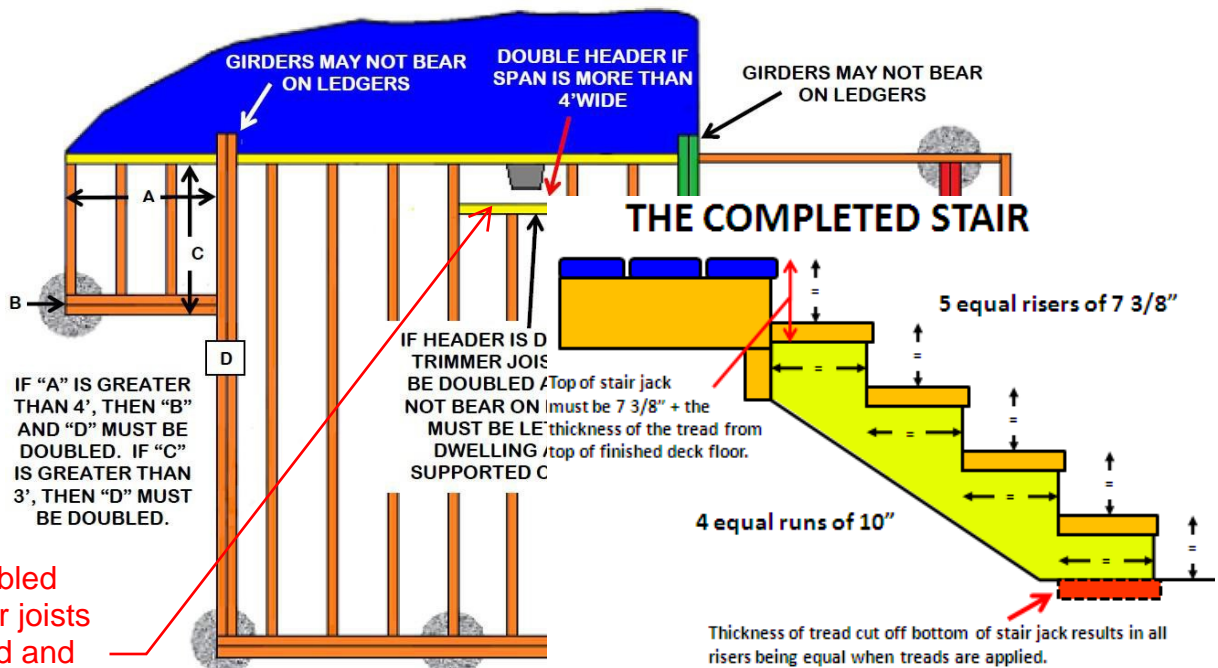
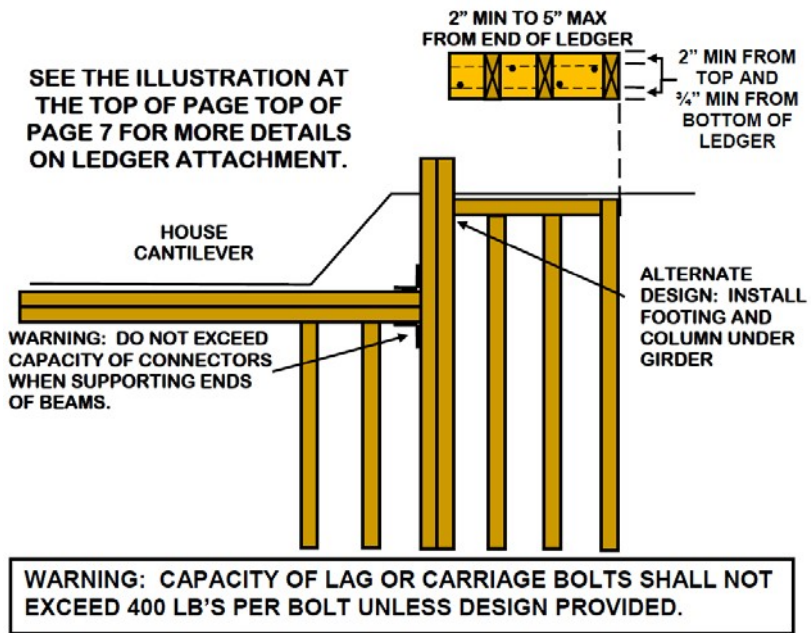

If header is doubled than the trimmer joists must be doubled and not bear on the cantilever.

Stairs must have a maximum rise of $7 \frac{3}{4}$ inches and a minimum run of 10 inches measured as shown. The greatest riser height within any flight of stairs shall not exceed the smallest by more than $\frac{3}{8}$ inch. The greatest tread depth within any flight of stairs shall not exceed the smallest by more than $\frac{3}{8}$ inch. **Open risers are permitted provided that a 4" diameter sphere will not pass between the treads.**

Stairs must be a minimum of 36 inches wide above the handrail and 31½ inches below the handrail.

STAIR TERMINOLOGY

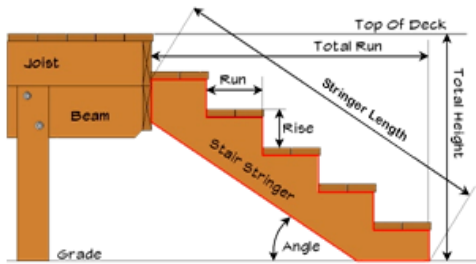

Stair Basics

- The maximum riser height is $7 \frac{3}{4}$ inches
- The minimum tread run is 10 inches
- Treads and risers should be approximately equal with the largest not exceeding the smallest by more than $\frac{3}{8}$ inch.

LAYING OUT STAIR JACKS

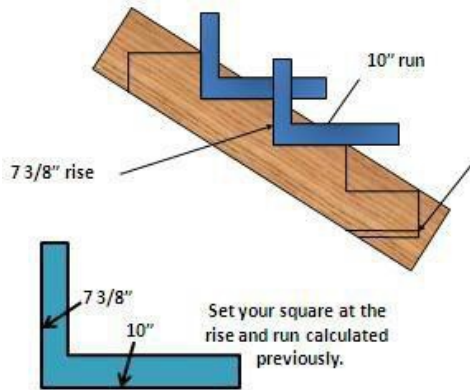

Cut an amount equal to the thickness of the tread from the bottom of the stair jack

DETERMINING RISE/RUN

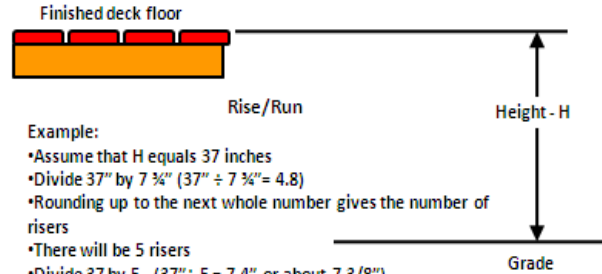

Example:

- Assume that H equals 37 inches
- Divide 37" by $7 \frac{3}{4}$ " ($37" \div 7 \frac{3}{4}" = 4.8$)
- Rounding up to the next whole number gives the number of risers
- There will be 5 risers
- Divide 37 by 5. ($37" \div 5 = 7.4"$ or about $7 \frac{3}{8}"$)
- Each riser will be $7 \frac{3}{8}"$
- For 5 risers there will be 4 treads
- Since each tread must be at least 10", the length of the stair from the face of the deck to the face of the bottom riser will be at least 40" ($10" \times 4 \text{ treads} = 40"$)

THE COMPLETED STAIR

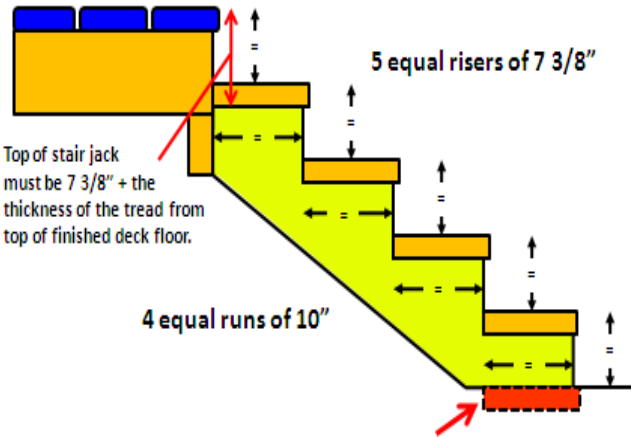

Thickness of tread cut off bottom of stair jack results in all risers being equal when treads are applied.

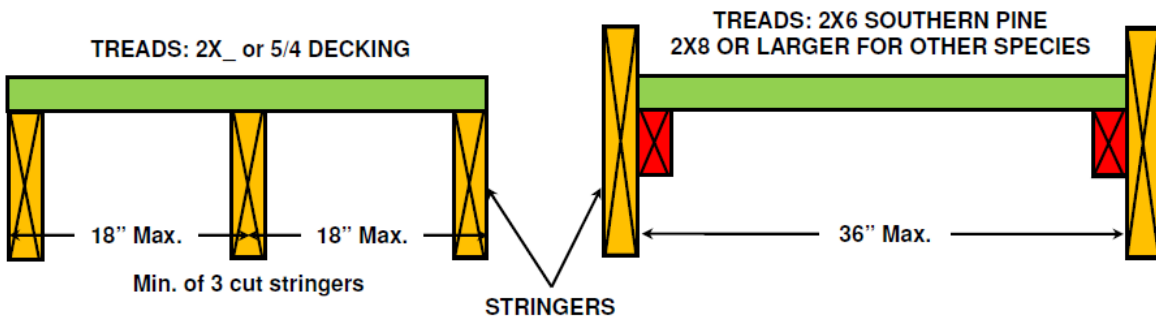

STAIR STRINGER SPANS
LANDINGS OR COLUMNS AND BEAMS MAY BE USED TO SHORTEN STRINGER SPANS

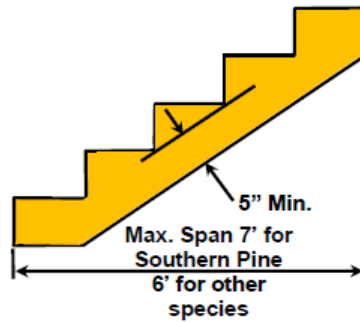

CUT STRINGER

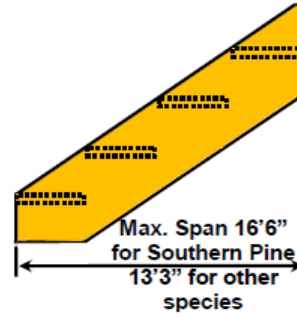

SOLID STRINGER

STAIR ATTACHMENTS

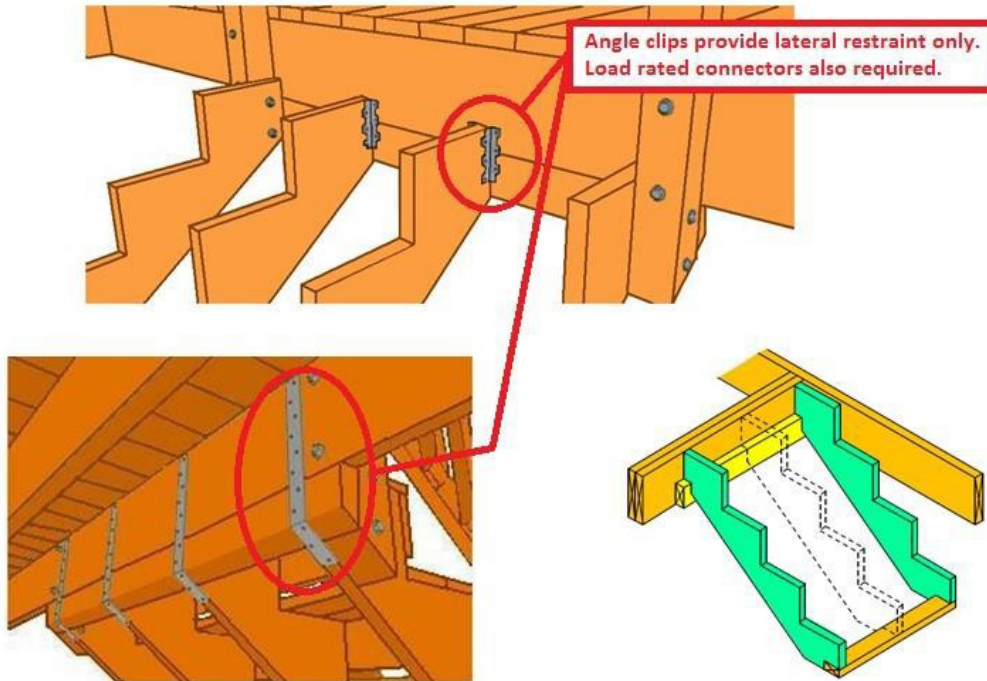

GUARDS AND HANDRAILS

Guards and handrails must be provided as shown on the following illustrations. Guards must continue down stairs where the stair is more than 30 inches above grade. The height of guards on stairs must be 34 inches minimum.

Handrails must be provided on at least one side when there are four or more risers. Handrails must have returns on each end or terminate in a newel post. Other handrail shapes having an equivalent gripping shape may be used with prior approval of the Building Department.

Handrails must be continuous for the entire length of the stairs and may not be interrupted by newel posts except at landings.

Handrails and guards must be designed to support a 200lb load applied in any direction at any point along the top of the guard or rail.

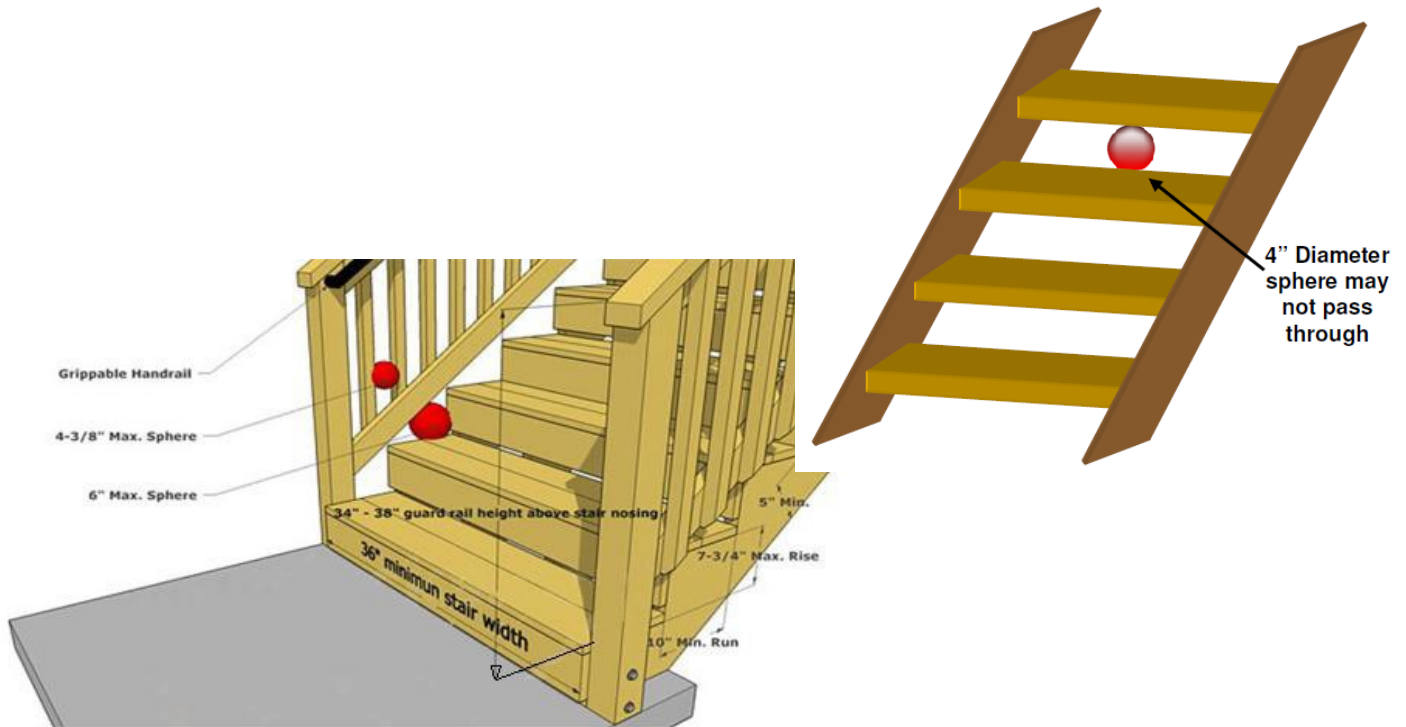

LANDING SHALL SPAN FULL WIDTH OF STAIRS & EXTEND A MINIMUM OF 36 INCHES IN THE DIRECTION OF TRAVEL.
STAIRS MUST BEAR ON STRUCTURAL MATERIAL (i.e. treated lumber, concrete, gravel) AND BE PERMANENTLY RESTRAINED FROM LATERAL MOVEMENT.

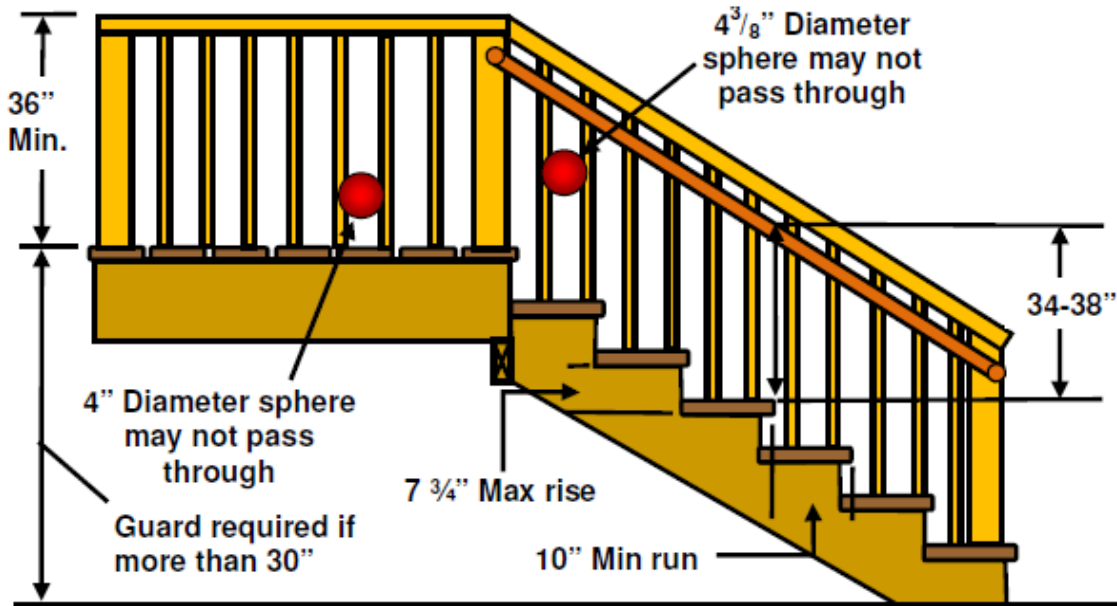

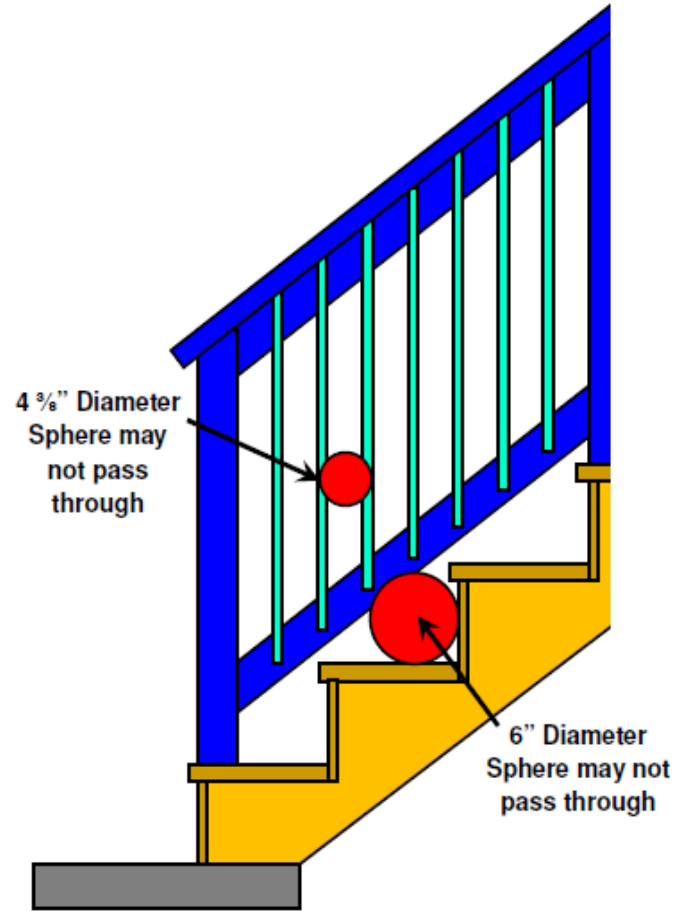
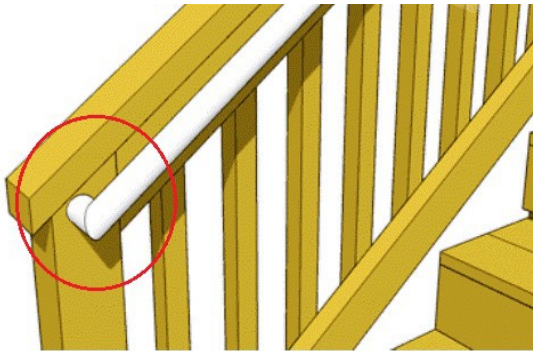

HANDRAILS MUST RETURN TO NEWEL POST AND BE CONTINUOUS WITHOUT INTERRUPTION FOR THE LENGTH OF THE FLIGHT INTERUPTION FOR THE LENGTH OF THE FLIGHT

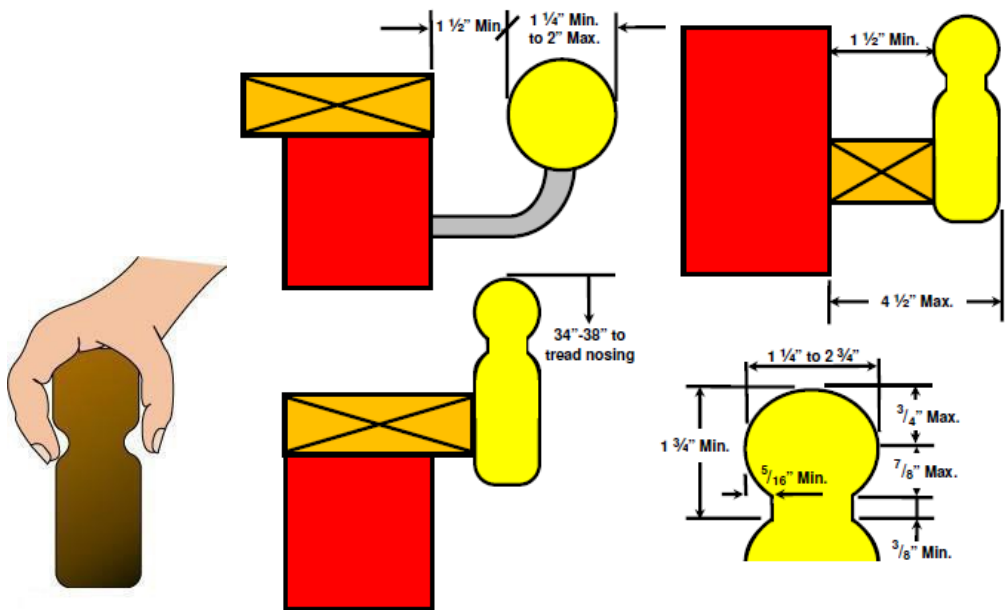

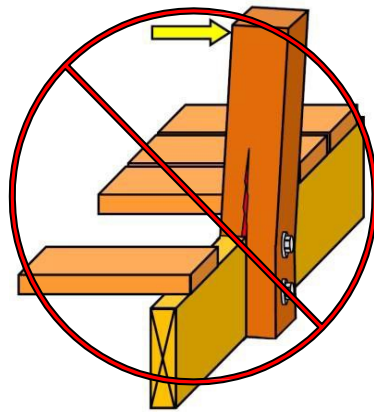
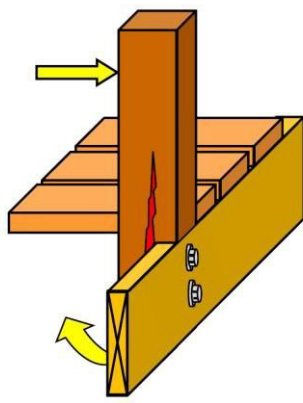

**AVOID NOTCHING
GUARD POSTS**

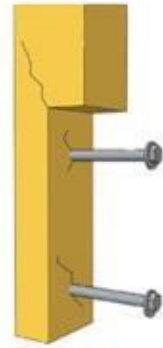

**BLOCKING MAY BE ADDED TO
STRENGTHEN POST ATTACHMENT**

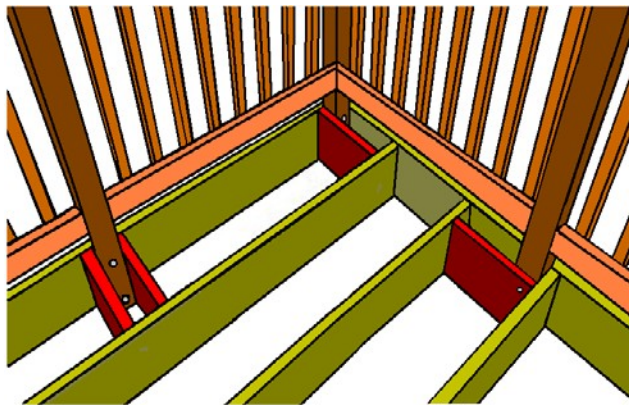

**Examples of Devices that can be
used to resist horizontal loads**

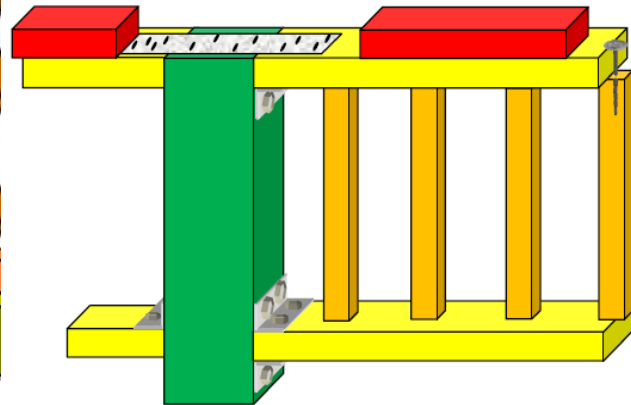

COMPOSITES AND OTHER DECK/RAILING PRODUCTS

Wood/plastic composites used for exterior deck boards, stair treads, handrails and guardrail systems must bear labels indicating compliance with ASTM D 7031 or a current ICC Evaluation Services Report must be made available.

Wood/plastic composites complying with ASTM D 7031 must be installed in accordance with the manufacturer's written installation instructions.

Wood/plastic composites having an ICC ES Report must be installed in accordance with the manufacturer's installation instructions and the report.

READ THE INSTRUCTIONS AND THE REPORTS CAREFULLY. ALL PRODUCTS HAVE SPECIFIC REQUIREMENTS FOR STAIR TREADS. SOME ARE LIMITED TO INSTALLATION PERPENDICULAR TO JOISTS ONLY.

PRODUCTS MADE OF ALUMINUM, STEEL, GLASS, OR ANY OTHER MAN MADE PRODUCT MAY BE USED IF THE MANUFACTURER HAS A RESEARCH REPORT FROM THE INTERNATIONAL CODE COUNCIL AND THE PRODUCT IS INSTALLED IN STRICT ACCORDANCE WITH THAT REPORT OR SITE SPECIFIC ENGINEERING IS PROVIDED.

Footing Sizes

		Posting Spacing															
		4'	5'	6'	7'	8'	9'	10'	11'	12'	13'	14'					
Joist Length	6"																
	Corner Footing	6 5 4	7 6 5	7 6 5	8 7 6	9 7 6	9 7 6	10 8 7	10 8 7	10 9 7	11 9 8	11 9 8	11 9 8	11 9 8	11 9 8	11 9 8	11 9 8
	Intermediate Footing	9 8 7	10 8 7	10 9 7	11 9 8	12 10 9	13 10 9	14 11 10	14 12 10	15 12 10	15 13 11	16 13 11	16 13 11	16 13 11	16 13 11	16 13 11	16 13 11
	7"																
	Corner Footing	7 5 5	7 6 5	8 7 6	9 7 6	9 8 7	10 8 7	10 8 7	11 9 8	11 9 8	12 10 9	12 10 9	12 10 9	12 10 9	12 10 9	12 10 9	12 10 9
	Intermediate Footing	9 8 7	10 8 7	11 9 8	12 10 9	13 11 9	14 11 10	15 12 10	15 13 11	16 13 11	17 14 12	17 14 12	17 14 12	17 14 12	17 14 12	17 14 12	17 14 12
	8"																
	Corner Footing	7 6 5	8 6 6	9 7 6	9 8 7	10 8 7	10 8 7	11 9 8	11 9 8	12 10 9	13 10 9	13 10 9	13 11 9	13 11 9	13 11 9	13 11 9	13 11 9
	Intermediate Footing	10 8 7	11 9 8	12 10 9	13 11 9	14 11 10	15 12 10	16 13 11	16 13 11	17 14 12	18 15 13	18 15 13	18 15 13	18 15 13	18 15 13	18 15 13	18 15 13
	9"																
	Corner Footing	7 6 5	8 7 6	9 7 6	10 8 7	10 9 7	11 9 8	12 10 8	12 10 9	13 10 9	13 11 9	13 11 9	14 11 10	14 11 10	14 11 10	14 11 10	14 11 10
	Intermediate Footing	10 9 7	12 10 8	13 10 9	14 11 10	15 12 10	16 13 11	17 14 12	17 14 12	18 15 13	19 15 13	19 15 13	20 16 14	20 16 14	20 16 14	20 16 14	20 16 14
	10"																
	Corner Footing	8 6 6	9 7 6	10 8 7	10 8 7	11 9 8	12 10 8	12 10 9	13 11 9	14 11 10	14 12 10	14 12 10	15 12 10	15 12 10	15 12 10	15 12 10	15 12 10
	Intermediate Footing	11 9 8	12 10 9	14 11 10	15 12 10	16 13 11	17 14 12	17 14 12	18 15 13	19 16 14	20 16 14	20 16 14	21 17 15	21 17 15	21 17 15	21 17 15	21 17 15
	11"																
Corner Footing	8 7 6	9 7 6	10 8 7	11 9 8	12 9 8	12 10 9	13 11 9	14 11 10	14 12 10	15 12 10	15 12 10	16 13 11	16 13 11	16 13 11	16 13 11	16 13 11	
Intermediate Footing	12 9 8	13 11 9	14 12 10	15 12 10	16 13 11	17 14 12	17 14 12	18 15 13	19 16 14	20 16 14	20 16 14	21 17 15	21 17 15	21 17 15	21 17 15	21 17 15	
12"																	
Corner Footing	9 7 6	10 8 7	10 9 7	11 9 8	12 10 9	13 10 9	14 11 10	14 12 10	15 12 10	15 13 11	15 13 11	16 13 11	16 13 11	16 13 11	16 13 11	16 13 11	
Intermediate Footing	12 10 9	14 11 10	15 12 10	16 13 11	17 14 12	18 15 13	19 16 14	20 16 14	21 17 15	22 18 15	22 18 15	23 18 15	23 18 15	23 18 15	23 18 15	23 18 15	
13"																	
Corner Footing	9 7 6	10 8 7	11 9 8	12 10 8	13 10 9	13 11 9	14 12 10	15 12 10	15 13 11	16 13 11	16 13 11	17 14 12	17 14 12	17 14 12	17 14 12	17 14 12	
Intermediate Footing	13 10 9	14 12 10	15 13 11	17 14 12	18 15 13	19 15 13	20 16 14	21 17 15	22 18 15	23 19 16	23 19 16	24 19 16	24 19 16	24 19 16	24 19 16	24 19 16	
14"																	
Corner Footing	9 8 7	10 8 7	11 9 8	12 10 9	13 11 9	14 11 10	15 12 10	15 13 11	16 13 11	17 14 12	17 14 12	18 15 13	18 15 13	18 15 13	18 15 13	18 15 13	
Intermediate Footing	13 11 9	15 12 10	16 13 11	17 14 12	18 15 13	20 16 14	21 17 15	22 18 15	23 18 15	24 19 16	24 19 16	25 20 17	25 20 17	25 20 17	25 20 17	25 20 17	
15"																	
Corner Footing	10 8 7	11 9 8	12 10 8	13 10 9	14 11 10	14 12 10	15 12 11	16 13 11	17 14 12	17 14 12	18 15 13	18 15 13	18 15 13	18 15 13	18 15 13	18 15 13	
Intermediate Footing	14 11 10	15 12 11	17 14 12	18 15 13	19 16 14	20 17 14	21 17 15	22 18 16	23 19 17	24 20 17	24 20 17	25 21 18	25 21 18	25 21 18	25 21 18	25 21 18	
16"																	
Corner Footing	10 8 7	11 9 8	12 10 9	13 11 9	14 11 10	15 12 10	16 13 11	16 13 12	17 14 12	18 15 13	18 15 13	19 16 14	19 16 14	19 16 14	19 16 14	19 16 14	
Intermediate Footing	14 11 10	16 13 11	17 14 12	18 15 13	20 16 14	21 17 15	22 18 16	23 19 16	24 20 17	25 21 18	25 21 18	26 21 18	26 21 18	26 21 18	26 21 18	26 21 18	

Notes :

1. Requirements for future 3-season porches or screen porches:
 - a . Increase corner footing size shown by 90%.
 - b . Increase center footing size shown by 55%.
 - c . Locate all footings at extremities of deck (no cantilevers) .

THREE

